

CHICAGO

Electric Power Tools

7-1/4" METAL CUTTING SAW

Model 8897

ASSEMBLY AND OPERATING INSTRUCTIONS



Distributed exclusively by Harbor Freight Tools®.

3491 Mission Oaks Blvd., Camarillo, CA 93011

Visit our website at: <http://www.harborfreight.com>



Read this material before using this product.

Failure to do so can result in serious injury.

SAVE THIS MANUAL.

Copyright® 2003 by Harbor Freight Tools®. All rights reserved. No portion of this manual or any artwork contained herein may be reproduced in any shape or form without the express written consent of Harbor Freight Tools. Diagrams within this manual may not be drawn proportionally. Due to continuing improvements, actual product may differ slightly from the product described herein. Tools required for assembly and service may not be included.

For technical questions or replacement parts, please call 1-800-444-3353.

PRODUCT SPECIFICATIONS



E194601

ITEM	DESCRIPTION
Electrical Requirements	120V / 60Hz / 10 Amps / 3500 RPM
Arbor Size	5/8" Diamond Arbor Hole
Saw Blade	7-1/4" Dia. x 36 Teeth x 5/8" Arbor Hole Tooth Tip: Metal Cutting Carbide Blade Rated Maximum RPM: 5,800
Maximum Depth of Cut	2-1/4"
Cutting Capacity (Metal)	.118" (3 MM) Minimum Thickness .275" (7 MM) Maximum Thickness
Additional Features	All Ball Bearing, Double Insulated Motor
Overall Dimensions	14-5/8" x 12" x 10"
Toe Plate Size	12-1/4" x 5-1/2"
Weight	13.8 Lbs.

SAVE THIS MANUAL

You will need this manual for the safety warnings and precautions, assembly, operating, inspection, maintenance and cleaning procedures, parts list and assembly diagram. Keep your invoice with this manual. Write the invoice number on the inside of the front cover. Keep this manual and invoice in a safe and dry place for future reference.

GENERAL SAFETY RULES

 **WARNING!**

READ AND UNDERSTAND ALL INSTRUCTIONS
Failure to follow all instructions listed below may result in
electric shock, fire, and/or serious injury.
SAVE THESE INSTRUCTIONS

WORK AREA

1. **Keep your work area clean and well lit.** Cluttered benches and dark areas invite accidents.

2. **Do not operate power tools in explosive atmospheres, such as in the presence of flammable liquids, gases, or dust.** Power tools create sparks which may ignite the dust or fumes.
3. **Keep bystanders, children, and visitors away while operating a power tool.** Distractions can cause you to lose control. Protect others in the work area from debris such as chips and sparks. Provide barriers or shields as needed.

ELECTRICAL SAFETY

4. **Grounded tools must be plugged into an outlet properly installed and grounded in accordance with all codes and ordinances. Never remove the grounding prong or modify the plug in any way. Do not use any adapter plugs. Check with a qualified electrician if you are in doubt as to whether the outlet is properly grounded.** If the tools should electrically malfunction or break down, grounding provides a low resistance path to carry electricity away from the user.
5. **Double insulated tools are equipped with a polarized plug (one blade is wider than the other). This plug will fit in a polarized outlet only one way. If the plug does not fit fully in the outlet, reverse the plug. If it still does not fit, contact a qualified electrician to install a polarized outlet. Do not change the plug in any way.** Double insulation eliminates the need for the three wire grounded power cord and grounded power supply system.
6. **Avoid body contact with grounded surfaces such as pipes, radiators, ranges, and refrigerators.** There is an increased risk of electric shock if your body is grounded.
7. **Do not expose power tools to rain or wet conditions.** Water entering a power tool will increase the risk of electric shock.
8. **Do not abuse the Power Cord. Never use the Power Cord to carry the tools or pull the Plug from an outlet. Keep the Power Cord away from heat, oil, sharp edges, or moving parts. Replace damaged Power Cords immediately.** Damaged Power Cords increase the risk of electric shock.
9. **When operating a power tool outside, use an outdoor extension cord marked “W-A” or “W”.** These extension cords are rated for outdoor use, and reduce the risk of electric shock.

PERSONAL SAFETY

10. **Stay alert. Watch what you are doing, and use common sense when operating a power tool. Do not use a power tool while tired or under the influence of drugs, alcohol, or medication.** A moment of inattention while operating power tools may result in serious personal injury.

11. **Dress properly. Do not wear loose clothing or jewelry. Contain long hair. Keep your hair, clothing, and gloves away from moving parts.** Loose clothes, jewelry, or long hair can be caught in moving parts.
12. **Avoid accidental starting. Be sure the Power Switch is off before plugging in.** Carrying power tools with your finger on the Power Switch, or plugging in power tools with the Power Switch on, invites accidents.
13. **Remove adjusting keys or wrenches before turning the power tool on.** A wrench or a key that is left attached to a rotating part of the power tool may result in personal injury.
14. **Do not overreach. Keep proper footing and balance at all times.** Proper footing and balance enables better control of the power tool in unexpected situations.
15. **Use safety equipment. Always wear eye protection.** Dust mask, non-skid safety shoes, hard hat, or hearing protection must be used for appropriate conditions.

TOOL USE AND CARE

16. **Use clamps (not included) or other practical ways to secure and support the workpiece to a stable platform.** Holding the work by hand or against your body is unstable and may lead to loss of control.
17. **Do not force the tool. Use the correct tool for your application.** The correct tool will do the job better and safer at the rate for which it is designed.
18. **Do not use the power tool if the Power Switch does not turn it on or off.** Any tool that cannot be controlled with the Power Switch is dangerous and must be replaced.
19. **Disconnect the Power Cord Plug from the power source before making any adjustments, changing accessories, or storing the tool.** Such preventive safety measures reduce the risk of starting the tool accidentally.
20. **Store idle tools out of reach of children and other untrained persons.** Tools are dangerous in the hands of untrained users.
21. **Maintain tools with care. Keep cutting tools sharp and clean.** Properly maintained tools with a sharp cutting edge are less likely to bind and are easier to control. Do not use a damaged tool. Tag damaged tools “Do not use” until repaired.

22. **Check for misalignment or binding of moving parts, breakage of parts, and any other condition that may affect the tool's operation. If damaged, have the tool serviced before using.** Many accidents are caused by poorly maintained tools.
23. **Use only accessories that are recommended by the manufacturer for your model.** Accessories that may be suitable for one tool may become hazardous when used on another tool.

SERVICE

24. **Tool service must be performed only by qualified repair personnel.** Service or maintenance performed by unqualified personnel could result in a risk of injury.
25. **When servicing a tool, use only identical replacement parts. Follow instructions in the “*Inspection, Maintenance, And Cleaning*” section of this manual.** Use of unauthorized parts or failure to follow maintenance instructions may create a risk of electric shock or injury.

GROUNDING

WARNING!

Improperly connecting the grounding wire can result in the risk of electric shock. Check with a qualified electrician if you are in doubt as to whether the outlet is properly grounded. Do not modify the power cord plug provided with the tool. Never remove the grounding prong from the plug. Do not use the tool if the power cord or plug is damaged. If damaged, have it repaired by a service facility before use. If the plug will not fit the outlet, have a proper outlet installed by a qualified electrician.

GROUNDED TOOLS: TOOLS WITH THREE PRONG PLUGS

1. Tools marked with “Grounding Required” have a three wire cord and three prong grounding plug. The plug must be connected to a properly grounded outlet. If the tool should electrically malfunction or break down, grounding provides a low resistance path to carry electricity away from the user, reducing the risk of electric shock. **(See Figure A, next page.)**
2. The grounding prong in the plug is connected through the green wire inside the cord to the grounding system in the tool. The green wire in the cord must be the only wire connected to the tool's grounding system and must never be attached to an electrically “live” terminal. **(See Figure A.)**

3. Your tool must be plugged into an appropriate outlet, properly installed and grounded in accordance with all codes and ordinances. The plug and outlet should look like those in the following illustration. **(See Figure A.)**

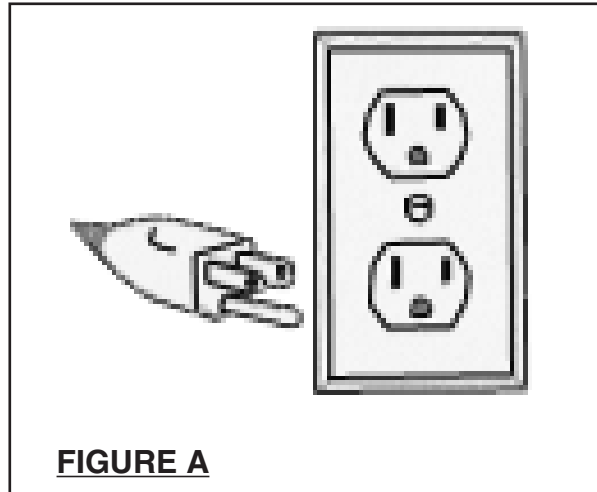

DOUBLE INSULATED TOOLS: TOOLS WITH TWO PRONG PLUGS

4. Tools marked “Double Insulated” do not require grounding. They have a special double insulation system which satisfies OSHA requirements and complies with the applicable standards of Underwriters Laboratories, Inc., the Canadian Standard Association, and the National Electrical Code. **(See Figure B.)**
5. Double insulated tools may be used in either of the 120 volt outlets shown in the following illustration. **(See Figure B.)**

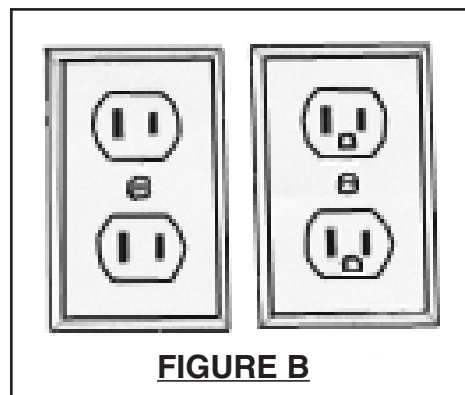

EXTENSION CORDS



1. **Grounded** tools require a three wire extension cord. **Double Insulated** tools can use either a two or three wire extension cord.
2. As the distance from the supply outlet increases, you must use a heavier gauge extension cord. Using extension cords with inadequately sized wire causes a serious drop in voltage, resulting in loss of power and possible tool damage. **(See Figure C, and Figure D, next page.)**
3. The smaller the gauge number of the wire, the greater the capacity of the cord. For example, a 14 gauge cord can carry a higher current than a 16 gauge cord. **(See Figure C, and Figure D.)**
4. If using more than one extension cord to make up the total length, make sure each cord contains at least the minimum wire size required. **(See Figure C, and Figure D.)**
5. If you are using one extension cord for more than one tool, add the nameplate amperes and use the sum to determine the required minimum cord size. **(See Figure C, and Figure D.)**
6. If you are using an extension cord outdoors, make sure it is marked with the suffix "W-A" ("W" in Canada) to indicate it is acceptable for outdoor use.
7. Make sure your extension cord is properly wired and in good electrical condition. Always replace a damaged extension cord or have it repaired by a qualified electrician before using it.
8. Protect your extension cords from sharp objects, excessive heat, and damp or wet areas.

RECOMMENDED MINIMUM WIRE GAUGE FOR EXTENSION CORDS* (120 VOLT)					
NAMEPLATE AMPERES (At Full Load)	EXTENSION CORD LENGTH				
	25 Feet	50 Feet	75 Feet	100 Feet	150 Feet
0 – 2.0	18	18	18	18	16
2.1 – 3.4	18	18	18	16	14
3.5 – 5.0	18	18	16	14	12
5.1 – 7.0	18	16	14	12	12
7.1 – 12.0	18	14	12	10	-
12.1 – 16.0	14	12	10	-	-
16.1 – 20.0	12	10	-	-	-

* Based on limiting the line voltage drop to five volts at 150% of the rated amperes.

FIGURE C

SYMBOLOLOGY

	Double Insulated
	Canadian Standards Association
	Underwriters Laboratories, Inc.
V ~	Volts Alternating Current
A	Amperes
no xxxx/min.	No Load Revolutions per Minute (RPM)

SPECIFIC SAFETY RULES

1. **Maintain a safe working environment.** Keep the work area well lit. Make sure there is adequate surrounding workspace. Always keep the work area free of obstructions, grease, oil, trash, and other debris. Do not use this product in areas near flammable chemicals, dusts, and vapors.
2. **Maintain labels and nameplates on the Saw.** These carry important information. If unreadable or missing, contact Harbor Freight Tools for a replacement.
3. **Use eye and hearing protection.** Always wear ANSI approved safety impact eye goggles and hearing protectors when using this product.
4. **Make sure to read and understand all instructions and safety precautions as outlined in the manufacturer's manual.**
5. **When using a hand-held power tool, always maintain a firm grip on the tool with both hands (at all times) to resist starting torque.**
6. **Always keep the Power Cord (71) away from moving parts of the Saw.** Keep the Power Cord away from the direction of the cut.
7. **Avoid unintentional starting.** Make sure you are prepared to begin work before turning on the Saw.
8. **Keep hands and fingers away from the Saw Blade (10) at all times.** If both hands are holding the Saw by its Handles (64, 65, 72), they cannot be cut by the Saw Blade.

9. **Do not reach underneath the workpiece.** The Blade Cover (20) can not protect you from the Saw Blade (10) below the work.
10. **Never hold the workpiece being cut in your hands or across your legs.** It is important to support the workpiece properly with clamps or other appropriate devices to minimize body exposure, blade binding, or loss of control.
11. **Keep your body positioned to either side of the Saw Blade (10), but not in line with the Saw Blade.** Kickback could cause the Saw to jump backwards.
12. **Causes and operator prevention of “kickback”:** Kickback is a sudden reaction to a pinched, bound, or misaligned Saw Blade (10), causing an uncontrolled Saw to lift up and out of the workpiece toward the operator. When the Saw Blade is pinched or bound tightly by the kerf closing down, the Saw Blade stalls and the motor reaction drives the tool rapidly back toward the operator. If the Saw Blade becomes twisted or misaligned in the cut, the teeth at the back edge of the Saw Blade can dig into the top surface of the workpiece causing the Saw Blade to climb out of the kerf and jump back toward the operator. Kickback is a result of tool misuse and/or incorrect operating procedures or conditions and can be avoided by taking proper precautions as given below:

A. Maintain a firm grip with both hands on the Saw, and position your body and arm to allow you to resist kickback forces. Kickback forces can be controlled by the operator if proper precautions are taken.

B. When the Saw Blade (10) is binding, or when interrupting a cut for any reason, release the Trigger Switch (66) and hold the Saw motionless in the workpiece until the Saw Blade comes to a complete stop. Never attempt to remove the Saw from the workpiece or pull the Saw backward while the Saw Blade is in motion or kickback may occur. Investigate and take corrective actions to eliminate the cause of Saw Blade binding.

C. When restarting a Saw in the workpiece, center the Saw Blade (10) in the kerf and check that the saw teeth are not engaged into the work-piece. If the Saw Blade is binding, it may walk up or kickback from the work-piece as the Saw is restarted.

D. Support large panels to minimize the risk of Saw Blade pinching and kickback. Large panels tend to sag under their own weight. Supports must be placed under the panel on both sides, near the line of cut and near the edge of the panel.



E. Do not use a dull or damaged Saw Blade (10). Unsharpened or improperly set Saw Blades produce a narrow kerf causing excessive friction, Saw

Blade binding and kickback.

F. The Saw Blade (10) depth adjusting Lock Lever (50) and Rip Guide Pins (29) must be kept tight and secure before making a cut. If Saw Blade adjustments shift while cutting, it may cause binding and kickback.

13. **Check the Blade Cover (12) for proper closing before each use. Do not operate the Saw if the Blade Cover does not move freely and close instantly. Never clamp or tie the Blade Cover into the open position.** If the Saw is accidentally dropped, the Blade Cover may be bent. Raise the Blade Cover and make sure it moves freely and does not touch the Saw Blade (10) or any other part, in all angles and depths of cut.
14. **Check the operation and condition of the Blade Cover Spring (13). If the Blade Cover and the Spring are not operating properly, they must be serviced before use.** The Blade Cover may operate sluggishly due to damaged parts, gummy deposits, or a build-up of debris.
15. **The Blade Cover (12) should be retracted manually only for special cuts such as “pocket cuts” and “compound cuts”. Raise the Blade Cover by its retracting handle. As soon as the Saw Blade (10) enters the workpiece, the Blade Cover must be released.** For all other sawing, the Blade Cover should operate automatically.
16. **Always observe that the Blade Cover (12) is covering the Saw Blade (10) before placing the Saw down on a bench or floor.** An unprotected, rotating Saw Blade will cause the Saw to walk backward, cutting whatever is in its path. Be aware of the time it takes for the Saw Blade to stop after the Trigger Switch (66) is released.
17. **Always hold the Saw by its insulated gripping surfaces when performing an operation where the cutting tool may accidentally contact wiring or its own Power Cord (71).** Contact with a “live” wire will also make exposed metal parts of the tool “live” and shock the operator.
18. **When ripping, always use the Rip Guide (73).** This improves the accuracy of the cut, and reduces the chance for Saw Blade (10) binding.
19. **Always use the proper size and type of Saw Blade (10): 7-1/4” diameter, metal cutting, 5,800 minimum rated RPM or greater.**

20. **Always use Saw Blades (10) with the correct size and shape (diamond vs. round) arbor holes.** Saw Blades that do not match the mounting hardware of the Saw will run eccentrically, causing loss of control.
21. **Never use damaged or incorrect Saw Blade (part #10) Inner/Outer Flanges (9, 11) or Screw (15).** The Inner and Outer Flanges and Screw were specially designed for this Saw, for optimum performance and safety of operation.
22. **Feed the Saw gradually into the workpiece.** Do not attempt to force the Saw to remove material faster than it was designed to cut.
23. **Secure the workpiece.** Whenever possible, secure the workpiece with a vise or clamps (not included).
24. **Make sure to remove all adjusting wrenches and tools before turning on the Saw.**
25. **Do not force the Saw.** This tool will do the work better and safer at the speed and capacity for which it was designed.
26. **Never leave the Saw unattended when it is plugged into an electrical outlet.** Turn off the tool, and unplug it from its electrical outlet before leaving.
27. **Reduce the risk of accidental starting.** Make sure the Trigger Switch (66) is in the “OFF” position before plugging the Power Cord (71) into a 120 volt, grounded, electrical outlet.
28. **Do not allow children to use or play with this product.**
29. **Store idle equipment.** When not in use, tools and equipment should be stored in a dry location to inhibit rust. Always lock up tools and equipment, and keep out of reach of children.
30. **Do not use this product if under the influence of alcohol or drugs.** Read warning labels on prescriptions to determine if your judgement or reflexes are impaired while taking drugs. If there is any doubt, do not attempt to use this product.
31. **Dress properly.** Do not wear loose clothing or jewelry as they can be caught in moving parts. Wear restrictive hair covering to contain long hair.
32. **Do not overreach.** Keep proper footing and balance at all times. Do not reach over or across running machines.
33. **Industrial applications must follow OSHA requirements.**

34. **Maintain this product with care.** Keep this product clean for better and safer performance.
35. **Maintenance:** For your safety, service and maintenance should be performed regularly by a qualified technician.
36. **Check for damaged parts.** Before using this product, carefully check that it will operate properly and perform its intended function. Check for damaged parts and any other conditions that may affect the operation of this product. Replace or repair damaged or worn parts immediately.
37. **Replacement parts and accessories:** When servicing, use only identical replacement parts. Only use accessories intended for use with this product.
38. **Use the right tool or attachment for the job.** Do not attempt to force a small tool or attachment to do the work of a larger industrial tool or attachment. There are certain applications for which this product was designed. It will do the job better and more safely at the rate for which it was intended. Do not modify this product, and do not use this product for a purpose for which it was not intended.
39. **Always turn off the Saw, and unplug it from its electrical outlet before performing any inspection or maintenance procedures.**
40.  **WARNING!** **Sparking Hazard.** Some metal cutting will create sparks. Do not cut near flammable materials, liquid or vapor. Always wear ANSI approved eye protection.
41.  **WARNING!** Some dust created by power sanding, sawing, grinding, drilling, and other construction activities, contain chemicals known (to the State of California) to cause cancer, birth defects or other reproductive harm. Some examples of these chemicals are: lead from lead-based paints, crystalline silica from bricks and cement or other masonry products, arsenic and chromium from chemically treated lumber. Your risk from these exposures varies, depending on how often you do this type of work. To reduce your exposure to these chemicals: work in a well ventilated area, and work with approved safety equipment, such as those dust masks that are specially designed to filter out microscopic particles. (*California Health & Safety Code § 25249.5, et seq.*)
42.  **WARNING!** People with pacemakers should consult their physician(s) before using this product. Operation of electrical equipment in close proximity to a heart pacemaker could cause interference or failure of the pacemaker.

UNPACKING

When unpacking, check to make sure all the parts shown on the **Parts Lists on pages 20 and 21** are included. If any parts are missing or broken, please call Harbor Freight Tools at the number shown on the cover of this manual as soon as possible.

ASSEMBLY INSTRUCTIONS

NOTE: For additional information regarding the parts mentioned in the following pages, refer to the **Assembly Diagram on page 22.**

To Attach The Rip Guide, And Adjust The Width Of A Cut:

1.  **WARNING!** Prior to performing this procedure, make sure the Trigger Switch (66) of the Saw is in its' "**OFF**" position and the Power Cord (71) is unplugged from its electrical outlet.
2. Slightly loosen the two Pins (29). **(See Figure D.)**
3. Slide the *arms* of the Rip Guide (73) through the slots in the Base (24). **(See Figure D.)**
4. Featured on the *arm* of the Rip Guide (73) is a width scale, divided in increments of 1/16". To adjust the width of the cut, slide the arm of the Rip Guide to the right or left until the desired width is acquired. Then, retighten the Pins (29) to hold the Rip Guide in place. **(See Figure D.)**



To Attach The Side Handle:

1. To attach the Side Handle (72), simply screw the Side Handle into the threaded mounting hole located in the upper/left Body (32) of the Saw. **(See Figure D.)**

To Adjust The Depth Of Cut:

1. **⚠ WARNING!** Prior to performing this procedure, make sure the Trigger Switch (66) of the Saw is in its “OFF” position and the Power Cord (71) is unplugged from its electrical outlet.
2. The Saw may be adjusted to cut to a *maximum* depth of **2-1/4”**.
3. When adjusting the depth of cut, always make sure the *teeth* of the Saw Blade (10) cut (or protrude) about 1/4” through the bottom surface of the workpiece.
4. To adjust the depth of cut, pull up on the Lock Lever (50) located at the rear of the Saw. **(See Figure E.)**
5. Raise or lower the Base (24) until the desired cutting depth is acquired. Then, push down on the Depth Control Lever (52) to lock the Base in place. **(See Figure E.)**

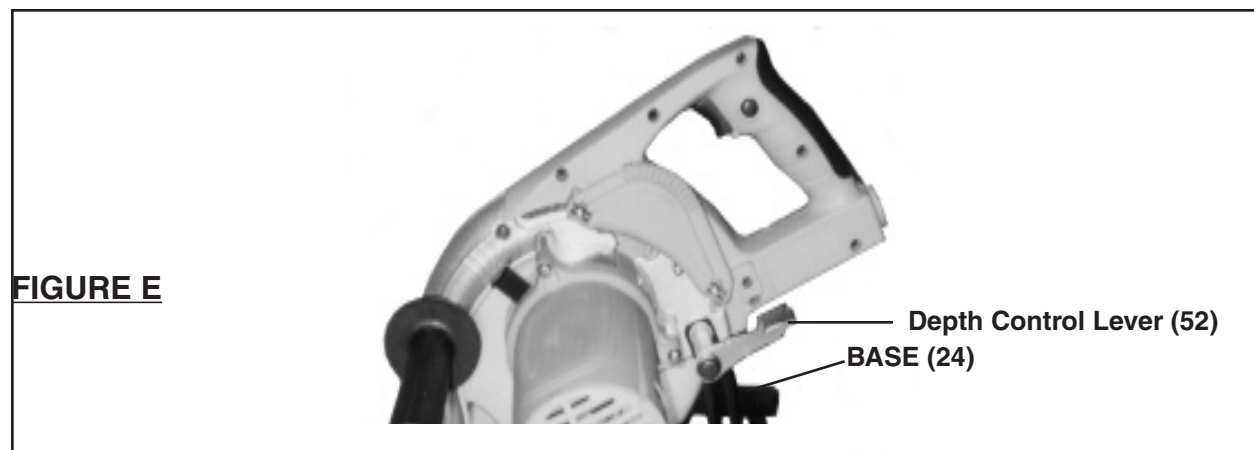

To Install A Saw Blade:

1. **⚠ WARNING!** Prior to performing this procedure, make sure the Trigger Switch (66) of the Saw is in its “OFF” position and the Power Cord (71) is unplugged from its electrical outlet.
2. **⚠ CAUTION!** Always make sure the Saw Blade (10) installed is a **7-1/4” diameter, metal cutting saw blade, with an RPM rating of 5,800 or greater.**

3. Turn the Knob (1) and remove the Plastic Cover (2). **(See Figure F.)**
4. Remove the *three* phillips Screws (33) located on the left side of the Body (32). **(See Figure G.)**

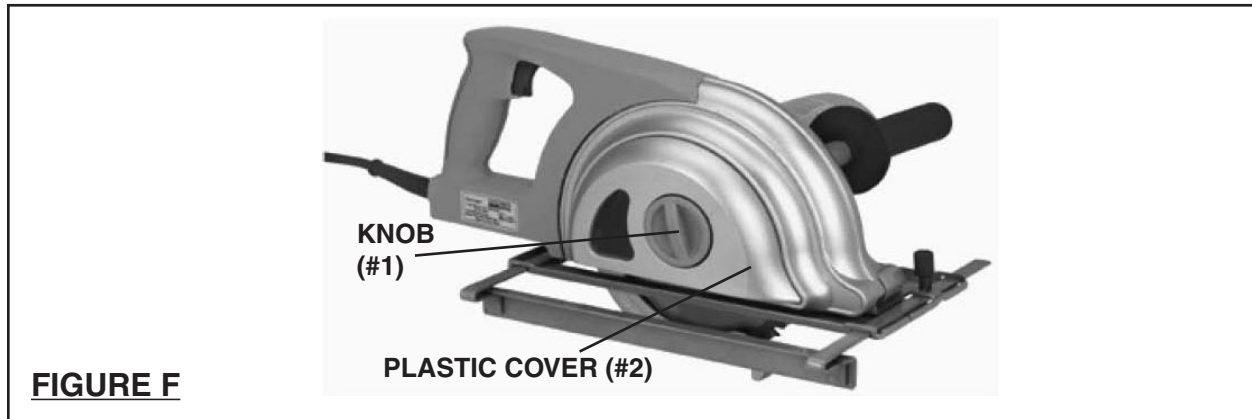

5. Depress the Depth Control Lever (52) and lower the Base (24) so that the Inner Cover (7) can be removed. **(See Figure G.)**

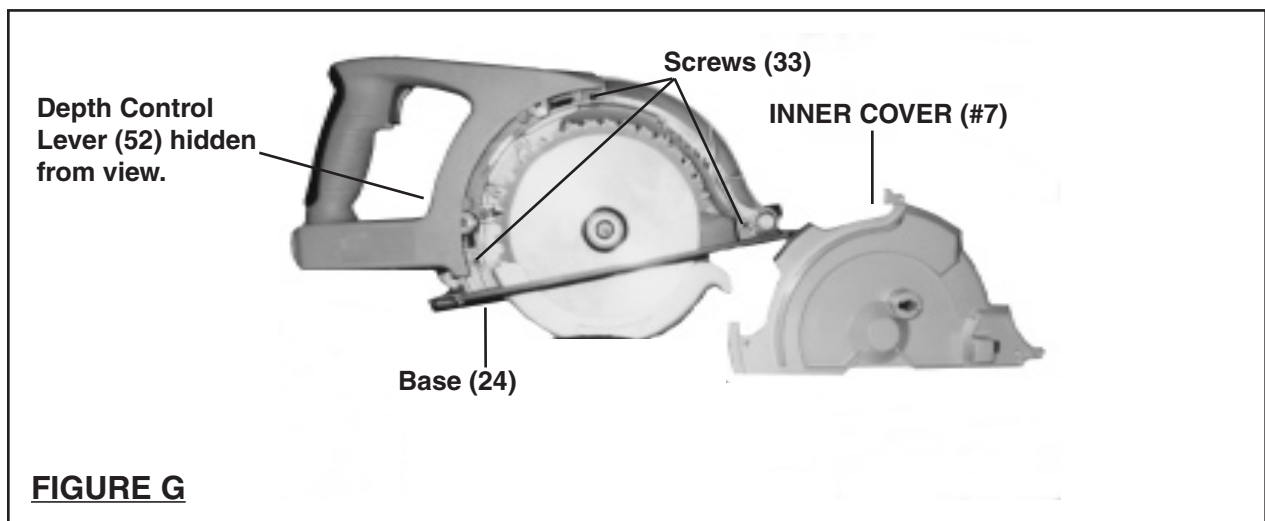

6. Depress the Depth Control Lever (52) to hold the Saw Blade (10) in place. Use the Blade Wrench (74) to unscrew and remove the Bolt (8). Release pressure on the Blade Lock Lever. **(See Figure H.)**
7. Remove the Outer Flange (11). Then, raise and hold the Blade Cover (12) in its “up” position while removing the Saw Blade. **(See Figure H.)**

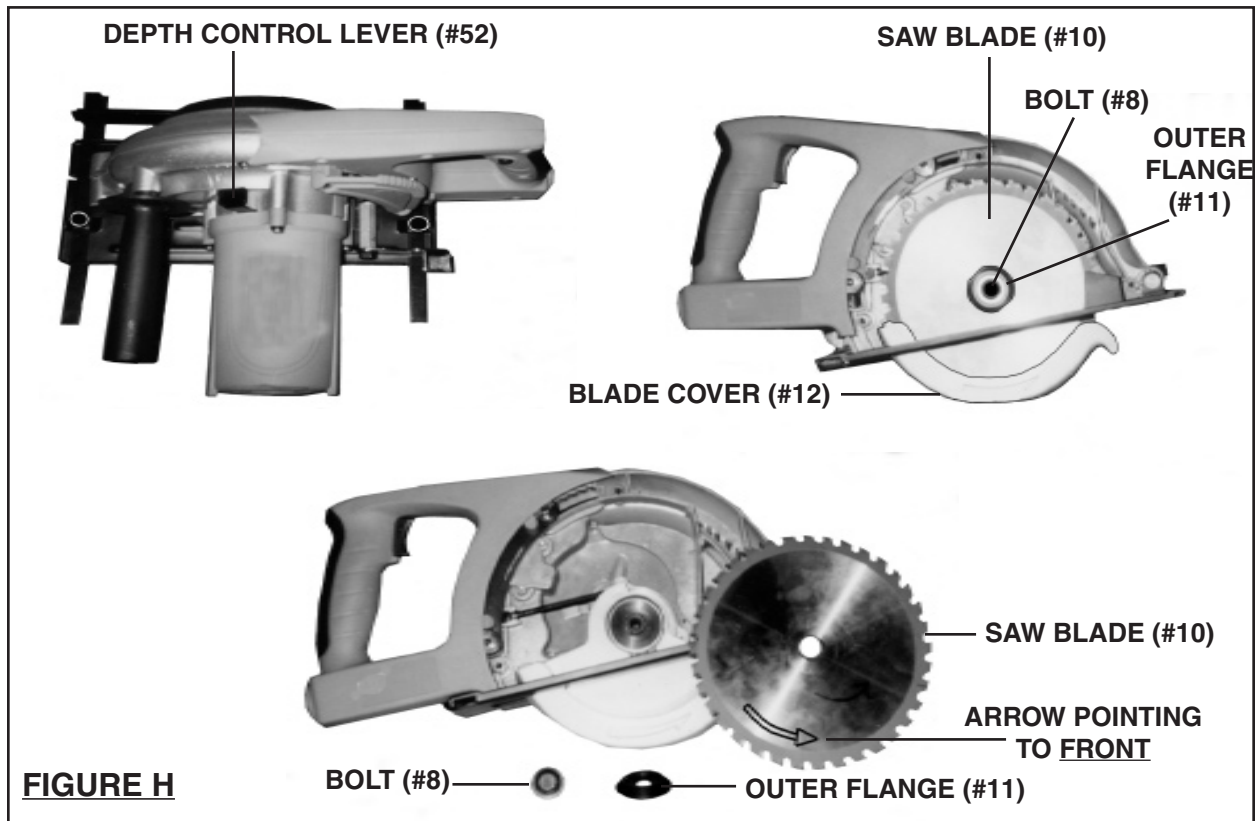

8. Raise and hold the Blade Cover (12) in its “up” position while installing the new Saw Blade (10). **IMPORTANT: When installing the new Saw Blade, make sure the arrow on the Saw Blade points to the front of the Saw.** **(See Figure H.)**
9. Replace the Outer Flange (11) and, while depressing the Depth Control Lever (52), use the Blade Wrench (74) to firmly tighten the Bolt (8) in place. **(See Figure H.)**
10. Replace the Inner Cover (7). Then replace the Plastic Cover (2), making sure to turn the Knob (1) to lock the Plastic Cover in place. **(See Figure H.)**
11. Replace the *three* phillips Screws (33) on the left side of the Body (32). **(See Figure F.)**

Proper Operation During The Cutting Process:

 **WARNING!** Never pass hands and fingers directly in front of, to the rear, or below, the Saw Blade (10) when cutting a workpiece. Always push the Saw into the workpiece with both hands firmly gripping the Handles (64, 65, 72).

1. Make all necessary adjustments to the Saw (width and depth) as previously discussed in this manual.
2. Make sure the workpiece is free from screws, rivets, and any other foreign objects which could damage the Saw Blade (10).
3. Make sure the workpiece is supported at all times. Whenever possible, secure the workpiece in a vise or with clamps (not included). If necessary, use a roller stand (not included) with larger workpieces.
4. Before trying new or complicated cutting techniques, study the procedure and practice with scrap metal.
5. Plug the Power Cord (71) into the nearest 120 volt, grounded, electrical outlet.
6. Firmly grip the Handles (64, 65, 72) of the Saw with both hands. Depress the Safety Lock Button (63), and squeeze the Trigger Switch (66) to turn on the Saw.
7. Allow the Saw Blade (10) to spin up to full speed before feeding the Saw Blade into the workpiece.
8. Make straight cuts only. Do not attempt to twist the Saw to the right or left while cutting. If this occurs, the Saw Blade (10) will “bind” in the workpiece causing kickback, potential personal injury, and/or damage to the workpiece and Saw.
9. Do not force the Saw to remove material faster than it was designed to cut. Make sure to feed the Saw Blade (10) *gradually* into the workpiece.
10. Turn off the Saw if the Saw Blade (10) is to be backed out of an uncompleted cut. When turning off the Saw, allow the Saw Blade to fully stop on its own before removing the Saw. Do not press against the Saw Blade to stop it.
11. Once the cutting job is completed, turn off the Saw and wait until the Saw Blade (10) has stopped rotating. Then, unplug the Power Cord (71) from its electrical outlet.

INSPECTION AND MAINTENANCE

1. **⚠️ WARNING!** Always unplug the Saw from its electrical outlet before performing any inspection, maintenance, or cleaning.
2. **Before each use:** Inspect the general condition of the Saw. Check for misalignment or binding of moving parts, loose, cracked or broken parts, damaged wiring, and any other condition that may affect its safe operation. If abnormal noise or vibration occurs, have the problem corrected before further use. **Do not use damaged equipment.**
3. **Daily:** The Saw Blade (10) must be sharp and clean to perform properly. Depending on materials cut and frequency of tool use, the Saw Blade may become clogged with metal particles and dull. Dull Saw Blades rub the workpiece rather than cut, which results in increased friction, higher temperatures, and a burned workpiece. As often as possible, check the condition of the Saw Blade and, if necessary, replace a worn Saw Blade with a new, 7-1/4" diameter, metal cutting Saw Blade rated at 5,800 RPM or above. **(See "To Install A Saw Blade" section for further information.)**
4. **DAILY:** With a vacuum or compressed air, remove all metal debris from the *metal debris compartment* of the Saw. To do so, lift up and open the Main Lock Plate (59) to expose the metal debris compartment. Once cleaned, close and lower the Main Lock Plate. **Do not immerse the Saw in liquid. (See Figure I.)**

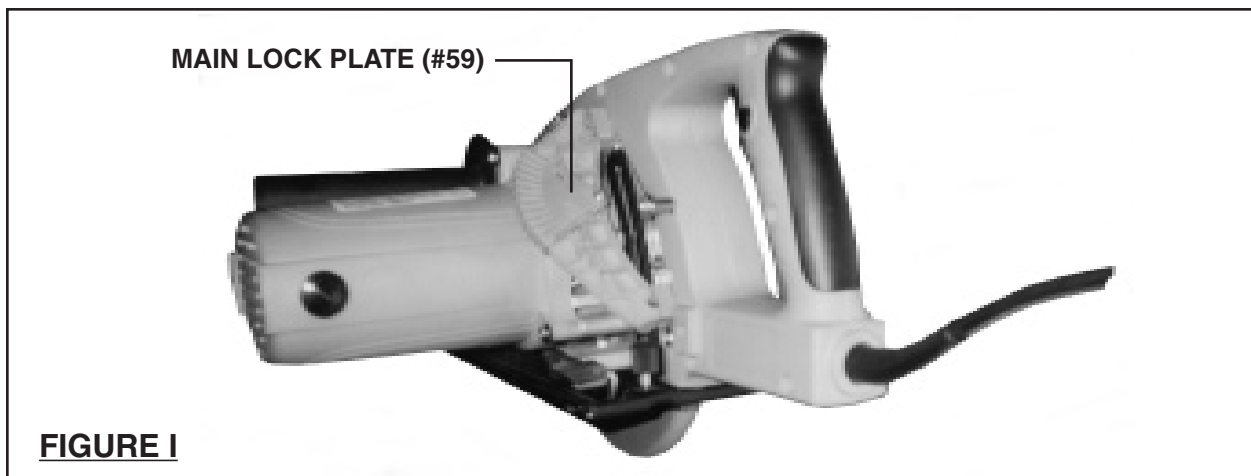

5. **Periodically:** The Saw features *two* Carbon Brushes (43) which, periodically, should be examined for wear. The Carbon Brushes are located on each side of the Motor Housing (41). To inspect or replace the Carbon Brushes, use a small standard screwdriver to remove the Brush Covers (42). Then, carefully pull out the Carbon Brushes. Examine the concave surface of the Carbon Brushes.

If the Carbon Brushes appear to be in good condition, but only dirty, they can be cleaned by rubbing with a pencil eraser. If there are large scratches on the Carbon Brushes, replace *both* Carbon Brushes immediately with approved replacement Carbon Brushes from Harbor Freight Tools. To reinstall the Carbon Brushes, insert them into the two Brush Holders (44). Turn the Carbon Brushes vertically so they will fit properly into the Brush Holders. Then, replace the Brush Covers. **(See Figure J.)**

6. Store the Saw in a clean, dry location.

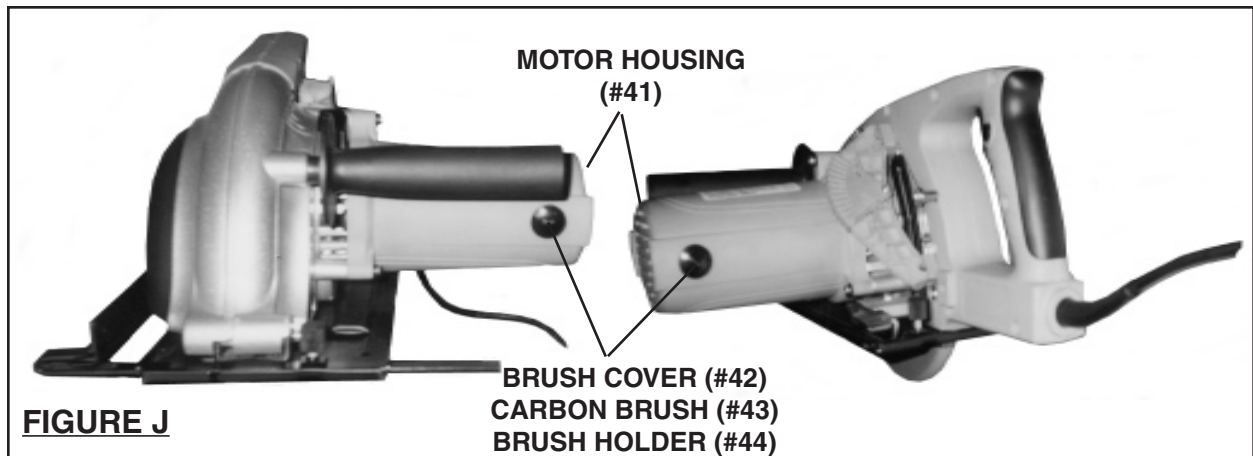

FIGURE J

PARTS LIST

Part #	Description	Part #	Description
1	Knob	28	Baffle
2	Plastic	29	Rip Guide Pin
3	Screw (M5)	30	Screw (M5)
4	Transparent Panel	31	Rubber Ring
5	Cover	32*	Body
6	Screw	33*	Screw (M5)
7	Inner Cover	34*	Bearing
8	Bolt (M8)	35*	Armature
9	Inner Flange	36*	Bearing
10	Saw Blade	37*	Ring Fender
11	Outer Flange	38*	Screw
12	Blade Cover	39*	Field
13	Spring	40*	Bearing Sleeve
14	Plastic Washer	41*	Motor Housing
15	Screw (M5)	42	Brush Cover
16	Bearing Retainer	43	Brush
17	Bearing	44	Brush Holder
18	Ring	45	Screw (M5)
19	Key	46	Nut
20	Arbor	47	Spring
21	Gear	48	Screw
22	Ring	49	Washer
23	Bearing	50	Lock Lever
24	Base	51	Ring
25	Spring	52	Depth Control Lever
26	Rivet	53	Washer
27	Screw	54	Screw (M8)

***NOTE: PARTS #32* THROUGH 41* MAY NOT BE ORDERED INDIVIDUALLY,
BUT MUST BE ORDERED AS A COMPLETE MOTOR ASSEMBLY (PART #76*).**

PARTS LIST (CONTINUED)

Part #	Description	Part #	Description
55	Outlet Box	66	Trigger Switch
56	Screw	67	Screw
57	Pin	68	Power Cord Clamp
58	Screw	69	Soft Grip
59	Main Lock Plate	70	Power Cord Guard
60	Spring	71	Power Cord
61	Vice Lock Plate	72	Side Handle
62	Washer	73	Rip Guide
63	Safety Lock Button	74	Blade Wrench
64	Handle (R)	76*	Motor Assembly
65	Handle (L)		

NOTE: Some parts are listed and shown for illustration purposes only, and are not available individually as replacement parts.

PLEASE READ THE FOLLOWING CAREFULLY

THE MANUFACTURER AND/OR DISTRIBUTOR HAS PROVIDED THE PARTS LIST AND ASSEMBLY DIAGRAM IN THIS MANUAL AS A REFERENCE TOOL ONLY. NEITHER THE MANUFACTURER OR DISTRIBUTOR MAKES ANY REPRESENTATION OR WARRANTY OF ANY KIND TO THE BUYER THAT HE OR SHE IS QUALIFIED TO MAKE ANY REPAIRS TO THE PRODUCT, OR THAT HE OR SHE IS QUALIFIED TO REPLACE ANY PARTS OF THE PRODUCT. IN FACT, THE MANUFACTURER AND/OR DISTRIBUTOR EXPRESSLY STATES THAT ALL REPAIRS AND PARTS REPLACEMENTS SHOULD BE UNDERTAKEN BY CERTIFIED AND LICENSED TECHNICIANS, AND NOT BY THE BUYER. THE BUYER ASSUMES ALL RISK AND LIABILITY ARISING OUT OF HIS OR HER REPAIRS TO THE ORIGINAL PRODUCT OR REPLACEMENT PARTS THERETO, OR ARISING OUT OF HIS OR HER INSTALLATION OF REPLACEMENT PARTS THERETO.

ASSEMBLY DIAGRAM

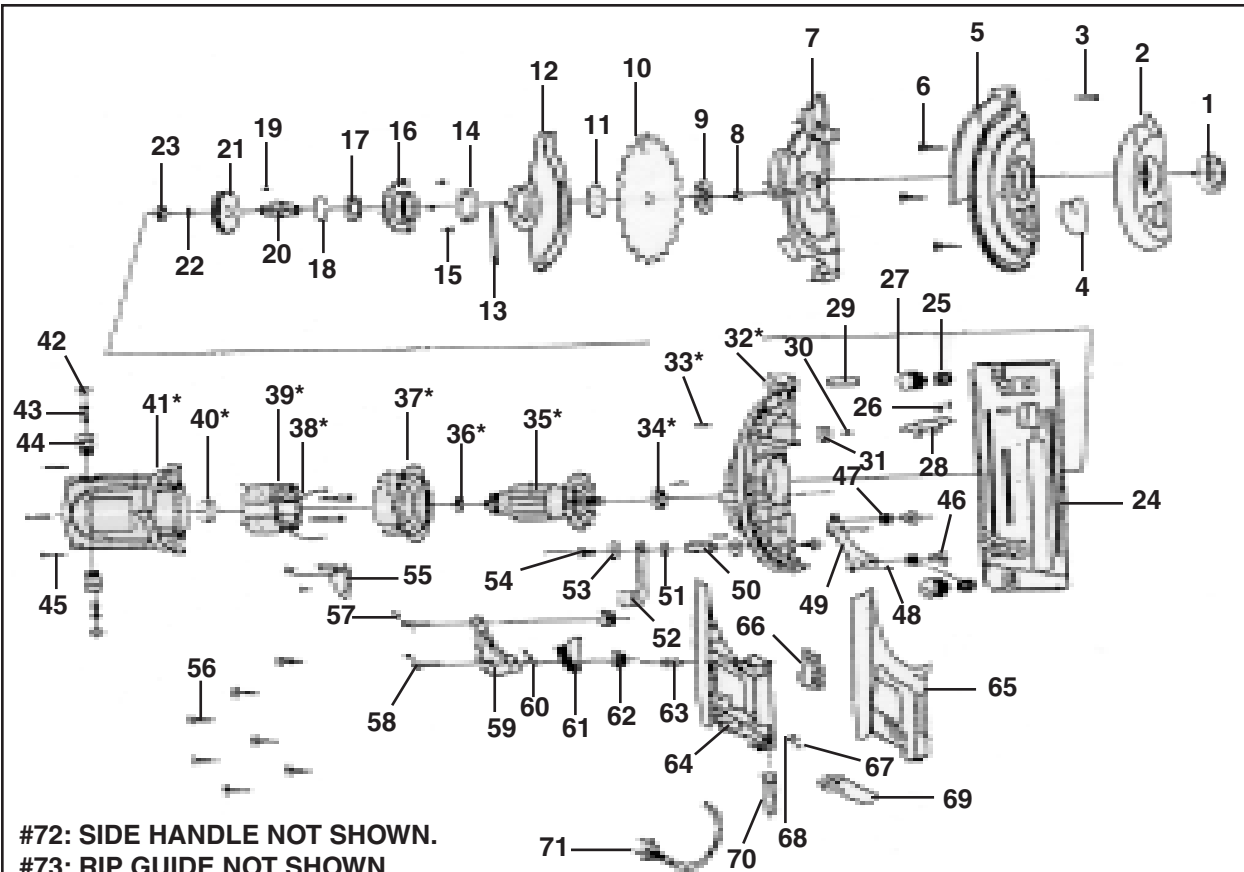

#72: SIDE HANDLE NOT SHOWN.
#73: RIP GUIDE NOT SHOWN.
#74: BLADE WRENCH NOT SHOWN.

***NOTE: PARTS #32* THROUGH 41* MAY NOT BE ORDERED INDIVIDUALLY, BUT MUST BE ORDERED AS A COMPLETE MOTOR ASSEMBLY (PART #76*).**

LIMITED 90 DAY WARRANTY

Harbor Freight Tools Co. makes every effort to assure that its products meet high quality and durability standards, and warrants to the original purchaser that this product is free from defects in materials and workmanship for the period of 90 days from the date of purchase. This warranty does not apply to damage due directly or indirectly, to misuse, abuse, negligence or accidents, repairs or alterations outside our facilities, criminal activity, improper installation, normal wear and tear, or to lack of maintenance. We shall in no event be liable for death, injuries to persons or property, or for incidental, contingent, special or consequential damages arising from the use of our product. Some states do not allow the exclusion or limitation of incidental or consequential damages, so the above limitation of exclusion may not apply to you. THIS WARRANTY IS EXPRESSLY IN LIEU OF ALL OTHER WARRANTIES, EXPRESS OR IMPLIED, INCLUDING THE WARRANTIES OF MERCHANTABILITY AND FITNESS.

To take advantage of this warranty, the product or part must be returned to us with transportation charges prepaid. Proof of purchase date and an explanation of the complaint must accompany the merchandise. If our inspection verifies the defect, we will either repair or replace the product at our election or we may elect to refund the purchase price if we cannot readily and quickly provide you with a replacement. We will return repaired products at our expense, but if we determine there is no defect, or that the defect resulted from causes not within the scope of our warranty, then you must bear the cost of returning the product.

This warranty gives you specific legal rights and you may also have other rights which vary from state to state.

3491 Mission Oaks Blvd. • PO Box 6009 • Camarillo, CA 93011 • (800) 444-3353